

1-Phase Solid State Contactors, High blocking voltage



Description

This slimline range of solid state contactors is an evolution of solid state switches for which Carlo Gavazzi is very well known. The RG solid state contactors present a unique opportunity for panel space savings thanks to their very slim footprint.

The **RGH** is the ready-to-use range that is provided with an integrated heatsink and carries a high blocking voltage specification of 1600 Vp. This makes the RGH more suitable for applications where uncontrolled transients may occur frequently. The output is still protected against overvoltages by means of an integrated varistor for situations where the uncontrolled transients exceed 1600 Vp.

The smallest footprint occupies a width of only 17.5 mm. Control ON indication is provided through a green LED. The RGH is available in E-type configuration with some variants available also in U-type configuration.

Specifications are at a surrounding temperature of 25°C unless otherwise specified.

Benefits

- **Suitable for harsh environments.** The RGH has a blocking voltage specification of 1600 Vp making it suitable for applications subject to frequent uncontrolled transients.
- **Panel space savings.** The slimmest product in the range accommodates up to 23 AAC in a width of only 17.5 mm.
- **Less maintenance costs.** Wire bonding technology reduces thermal and mechanical stresses of the output chips resulting in a larger number of operational cycles compared to other assembly technologies.
- **Low machine downtime.** Integrated overvoltage protection prevents the solid state relay from breaking down due to uncontrolled transients exceeding 1600 Vp that may occur on the lines.
- **Ease of use.** The RGH ready-to-use solution is provided with integrated heatsink thus eliminating the need for the user to calculate the size of heatsink needed for adequate thermal dissipation.
- **Cost effective protection co-ordination.** The high I^2t specification permits easy Type 2 protection co-ordination with B-type Miniature Circuit Breakers.
- **Fast wiring.** Power connections for models rated >30 A are equipped with terminals that can handle cables up to 25 mm² / AWG3 cables. Spring loaded control terminals are also available that help reduce installation time.
- **Accommodates UL508A requirements for Industrial Control Panels.** The RGH is certified as a listed product. All models carry a 100 kArms Short Circuit Current Rating.

Applications

Plastic injection machines, extrusion machines, blow moulding machines, thermoformers, dryers, electrical ovens, fryers, shrink tunnels, air handling units, sterilisation equipment, climatic chambers, ovens and furnaces, ambient heating.

Main features

- Ratings up to 759 VAC, 60 A @ T_A 40°C
- 1600 Vp for blocking voltage with integrated over voltage protection
- 100 kA short circuit current rating according to UL508
- Conformance to Railway standards

Order code

 **RGH1A**

Enter the code option instead of . Refer to the selection guide section for valid part numbers.

Code	Option	Description	Comments
R	-	Solid State Relay (RG)	
G	-		
H	-	With integrated heatsink	1600 Vp blocking voltage
1	-	1-pole switching	
A	A	Zero Cross switching (ZC)	
<input type="checkbox"/>	60	Rated voltage: 42-660 VAC	
	69	Rated voltage: 42-759 VAC	
<input type="checkbox"/>	D	Control voltage: 4-32 VDC	
	A	Control voltage: 20-275 VAC, 24-190 VDC	
<input type="checkbox"/>	15	Rated current: 23 AAC (6600 A ² s)	17.5 mm wide, low depth
	31	Rated current: 30 AAC (6600 A ² s)	22.5 mm wide
	41	Rated current: 40 AAC (6600 A ² s)	35 mm wide
	60	Rated current: 60 AAC (6600 A ² s)	70 mm wide
<input type="checkbox"/>	K	Screw connection for control terminals	
	M	Pluggable spring-loaded connection for control terminals	Applicable only to: RGH..D..
<input type="checkbox"/>	K	Screw connection for power terminals	Applicable only to: RGH..15, 31
	G	Box clamp connection for power terminals	Applicable only to: RGH..41, 60
<input type="checkbox"/>	E	Contact configuration	
	U	SSR configuration	Applicable only to: RGH..D41, 60
<input type="checkbox"/>	-		Single packaging
	X20	Bulk packaging of 20 pcs.	Applicable only to: RGH..15

Selection guide

For E - type configuration:

Rated voltage, Blocking voltage, Switching mode	Control voltage	Rated operational current @ 40°C			
		23 AAC (6600 A²s)	30 AAC (6600 A²s)	40 AAC (6600A²s)	60 AAC (6600 A²s)
		Product width			
		17.5 mm, low depth	22.5 mm	35 mm	70 mm
600 VAC, 1600 Vp ZC	4 - 32 VDC	RGH1A60D15KKE RGH1A60D15MKE	RGH1A60D31KKE RGH1A60D31MKE	RGH1A60D41KGE -	RGH1A60D60KGE -
	20-275 VAC, 24-190 VDC	RGH1A60A15KKE	RGH1A60A31KKE	RGH1A60A41KGE	RGH1A60A60KGE
690 VAC, 1600 Vp ZC	4 - 32 VDC	-	-	RGH1A69D41KGE	RGH1A69D60KGE
	20-275 VAC, 24-190 VDC	-	-	RGH1A69A41KGE	RGH1A69A60KGE

For U - type configuration:

Rated voltage, Blocking voltage, Switching mode	Control voltage	Rated operational current @ 40°C			
		-	-	40 AAC (6600A²s)	60 AAC (6600 A²s)
		Product width			
		-	-	35 mm	70 mm
600 VAC, 1600 Vp ZC	4 - 32 VDC	-	-	RGH1A60D41KGU	RGH1A60D60KGU

KKE: input terminals = screw	output terminals = screw
KGE: input terminals = screw	output terminals = box clamp
MKE: input terminals = pluggable spring	output terminals = screw
MGE: input terminals = pluggable spring	output terminals = box clamp
KGU: input terminals = screw	output terminals = box clamp

Carlo Gavazzi compatible components

Description	Component code	Notes
Control Plugs	RGM25	Pack of 10 spring loaded control plugs

Carlo Gavazzi further reading

Information	Where to find it	Notes
Datasheet	https://gavazziautomation.com/images/PIM/DATASHEET/ENG/rgc.pdf	Solid state contactor, RGC with 'E' - type configuration
Datasheet	https://gavazziautomation.com/images/PIM/DATASHEET/ENG/rgc_u.pdf	Solid state contactor, RGC with 'U' - type configuration

Structure

RGH..KKE

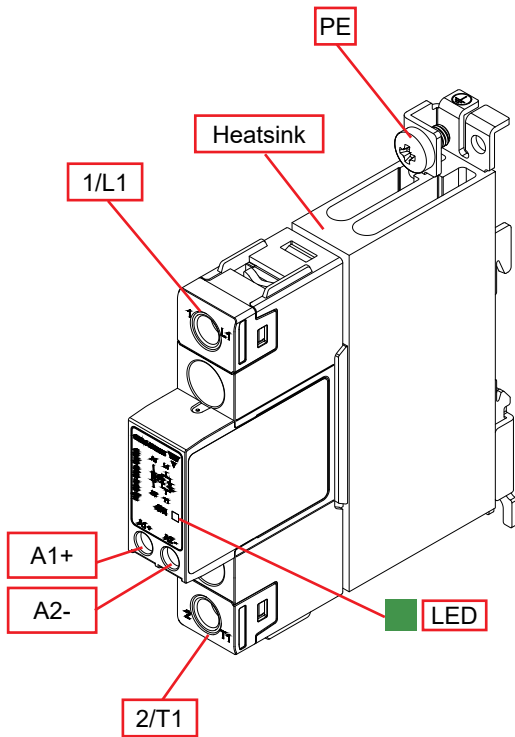

RGH..KGE

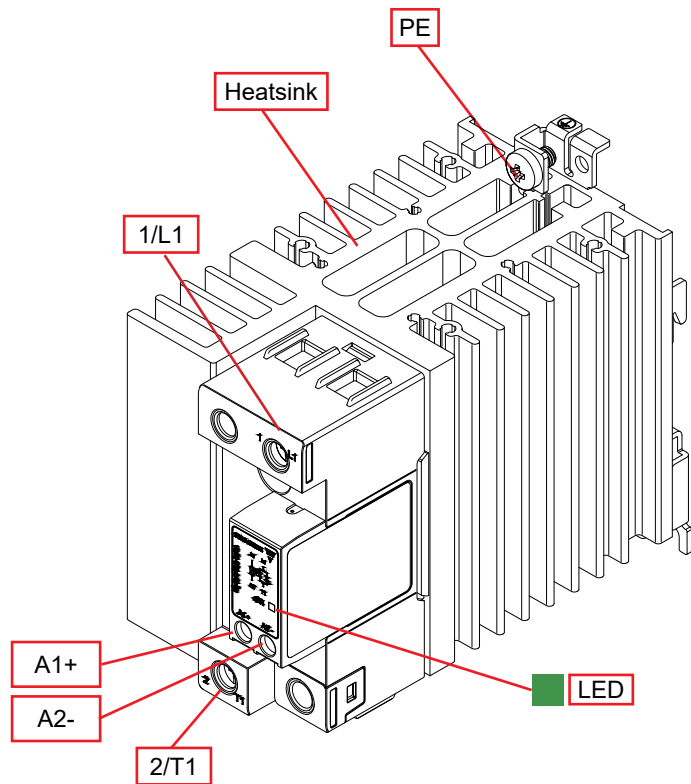

Element	Component	Function
1/L1	Power connection	Mains connection
2/T1	Power connection	Load connection
A1+, A2-	Control connection	Terminals for control voltage
LED	ON indicator	Indicates presence of control voltage
Heatsink	Integrated heatsink	DIN rail mounting (panel mounting also possible)
PE	Protective Earth	Connection for Protective Earth, PE screw not provided with RGH

Note: For U- type configuration please refer to Dimensions and Terminal layout sections.

Features

General data

Material	PA66 or PA6 (UL94 V0), RAL7035 Glow wire ignition temperature and Glow wire flammability index conform to EN 60335-1 requirements	
Mounting	DIN rail (panel mount also possible)	
Touch Protection	IP20	
Overvoltage Category	III, 6 kV (1.2/50 μ s) rated impulse withstand voltage	
Isolation	Input and Output to Case: Input to Output:	4000 Vrms 4000 Vrms
Weight	RGH..15: RGH..31: RGH..41: RGH..60:	approx. 260 g approx. 375 g approx. 515 g approx. 972 g

Performance

Output specifications

	RGH..15	RGH..31	RGH..41	RGH..60
Max. operational current¹: AC-51 @ Ta=25°C	23 AAC	30 AAC	49 AAC	75 AAC
Max. operational current¹: AC-51 @ Ta=40°C	23 AAC	30 AAC	40 AAC	60 AAC
Max. operational current^{1,3}: AC-53a @ Ta=40°C	5 AAC	10 AAC	13 AAC	18 AAC
Operational frequency range	45 to 65 Hz			
Output protection	Integrated varistor ⁴			
Leakage current @ rated voltage	<3 mAAC			
Minimum operational current	400 mAAC	400 mAAC	400 mAAC	400 mAAC
Repetitive overload current (Motor rating) UL508: Ta=40°C, t_{ON}=1 s, t_{OFF}=9 s, 50 cycles	51 AAC	84 AAC	126 AAC	144 AAC
Non-repetitive surge current (I_{TSM}), t=10 ms	1150 Ap	1150 Ap	1150 Ap	1150 Ap
I²t for fusing (t=10 ms), min.	6600 A ² s	6600 A ² s	6600 A ² s	6600 A ² s
No. of motor starts per hour² (x=6, Tx=6s, F=50%) @ 40°C	30			
Power factor	>0.5 at rated voltage			
Critical dV/dt (@Tj init = 40°C)	1000 V/ μ s			

1. Refer to Current derating curves
2. Overload profile for AC-53a;
Ie: AC-53a: xIe-Tx: F-S, where Ie = nominal current (AC-53a AAC), xIe = overload current factor, Tx = duration of overload current (s), F = duty cycle (%), S = number of starts per hour. Example; 5A: AC-53a: 6 - 6 : 50 - 30 = max. 30 starts for the RGH..15 with an overload profile of 30A for 6 seconds with a duty cycle of 50%
3. The AC53a value depends on the specific overload profile and can change based on the overload characteristics. For example:
the RGH..15 is rated with an AC53a rating of 16A for an overload profile of: 16A: AC53a: 5-1 : 50-10
the RGH..31 is rated with an AC53a rating of 16A for an overload profile of: 16A: AC53a: 6-1 : 75-10
4. Varistor on output is not included in the RGH1A69...models

Output voltage specifications

	RGH1A60..	RGH1A69..
Operational voltage range	42-600 VAC, +10% -15% on max	42-690 VAC ⁵ , +10% -15% on max
Blocking voltage	1600 Vp	
Internal varistor	680 V	-

5: 690 VAC refers to the line to line voltage

Motor ratings: HP (UL508) / kW (EN/IEC 60947-4-2) @ 40°C

	115 VAC	230 VAC	400 VAC	480 VAC	600 VAC	690 VAC
RGH..15	1/8HP / 0.18kW	1HP / 0.37kW	2HP / 0.75kW	3HP / 1.1kW	3HP / 1.5kW	- / 1.5kW
RGH..31	3/4HP / 0.37kW	2HP / 1.1kW	3HP / 1.5kW	5HP / 2.2kW	5HP / 3.7kW	- / 3.7kW
RGH..41	1 1/2HP / 0.56kW	3HP / 1.5kW	5HP / 2.2kW	7 1/2HP / 3.7kW	10HP / 4kW	- / 4kW
RGH..60	2HP / 0.75kW	3HP / 1.5kW	5HP / 4kW	7 1/2HP / 4kW	10HP / 5.5kW	- / 5.5kW

Inputs

	RGH..D..	RGH..A..
Control voltage range	4 - 32 VDC	20-275 VAC, 24 (-10%) -190 VDC
Control voltage frequency range	-	45 to 65 Hz
Pick-up voltage	3.8 VDC	20 VAC/DC
Drop-out voltage	1.0 VDC	5 VAC/DC
Maximum reverse voltage	32 VDC	-
Maximum response time	0.5 cycle + 500 μs @ 24 VDC	2 cycles @ 230 VAC/110 VDC
Response time drop-out	0.5 cycle + 500 μs @ 24 VDC	0.5 cycle + 40 ms @ 230 VAC/110 VDC
Input current @ 40°C	See diagrams below	

Input current vs. input voltage

RGH..D

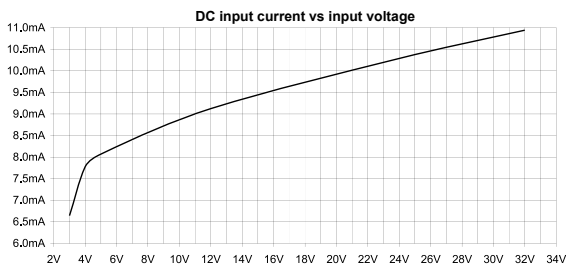

RGH..A

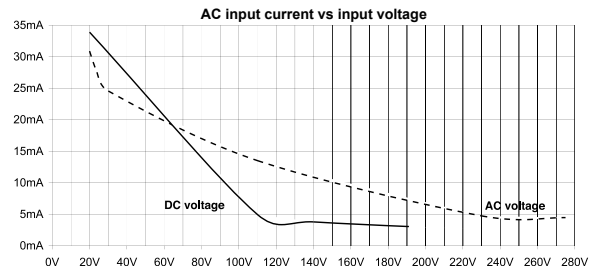

Output power dissipation

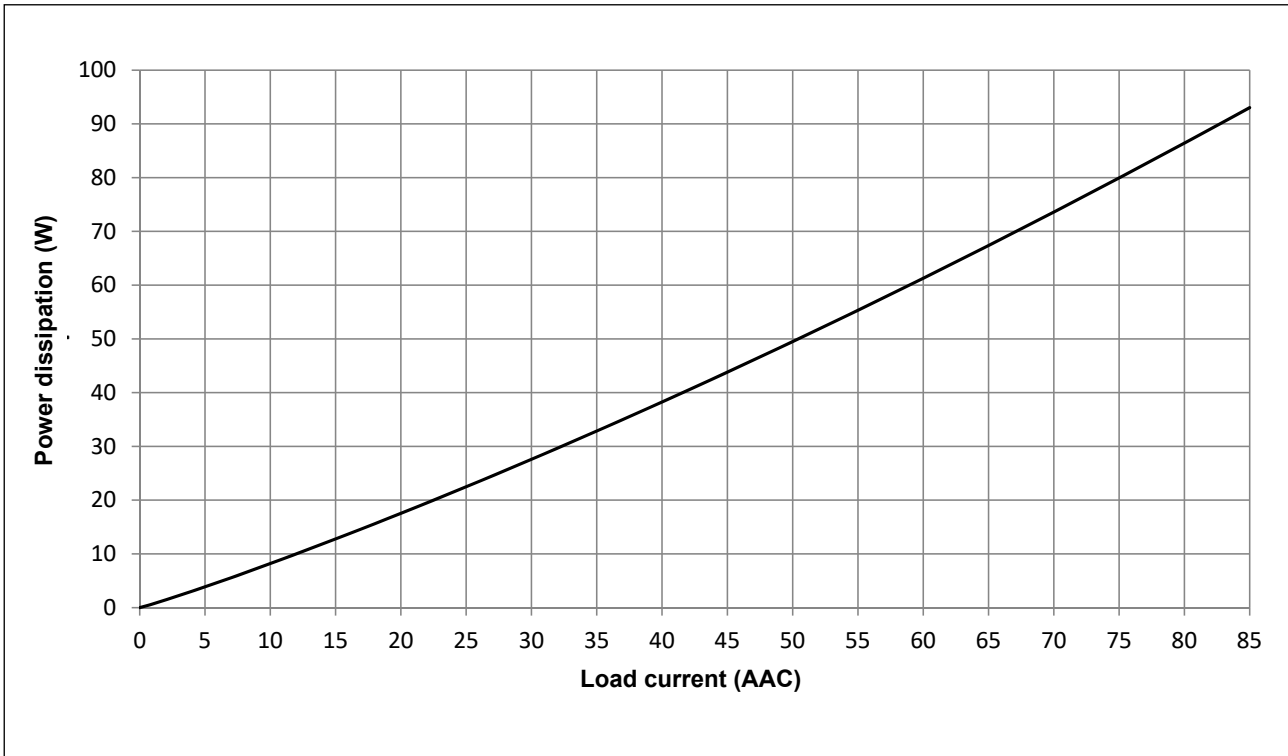



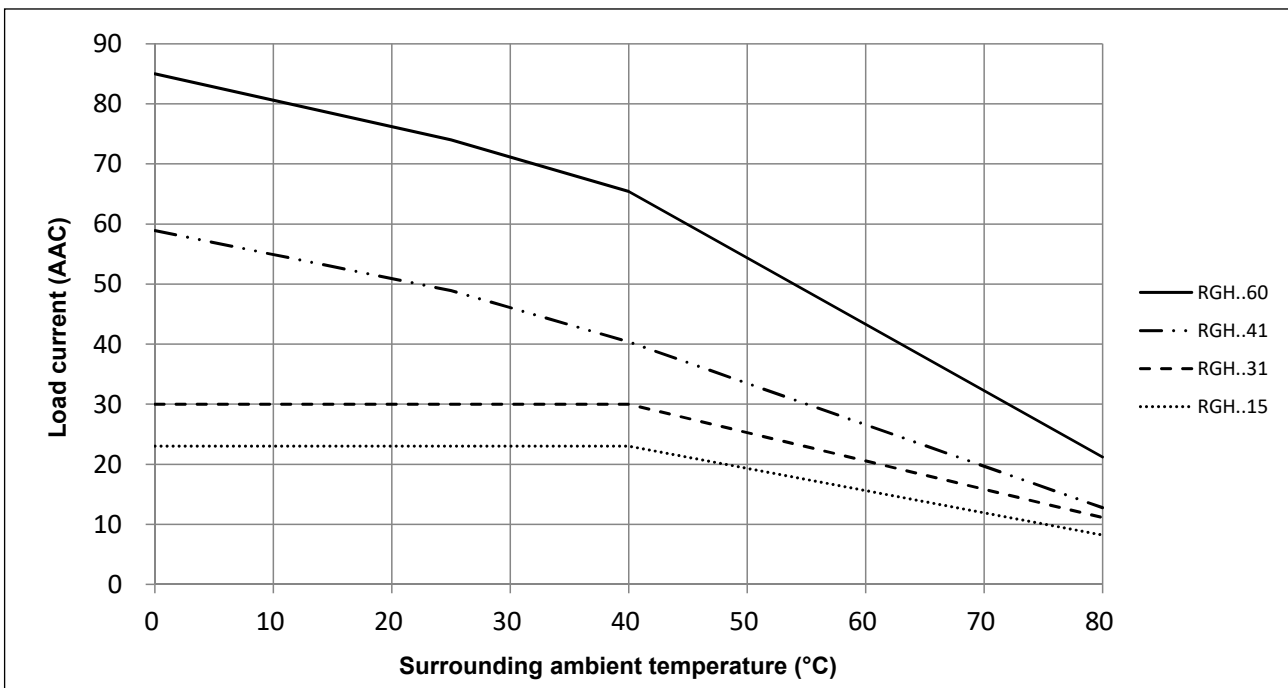

Current derating

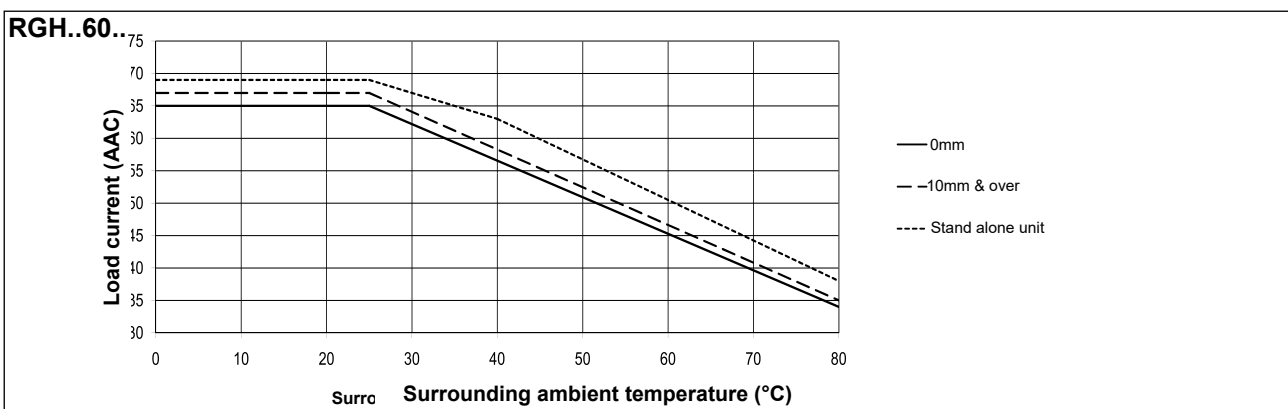
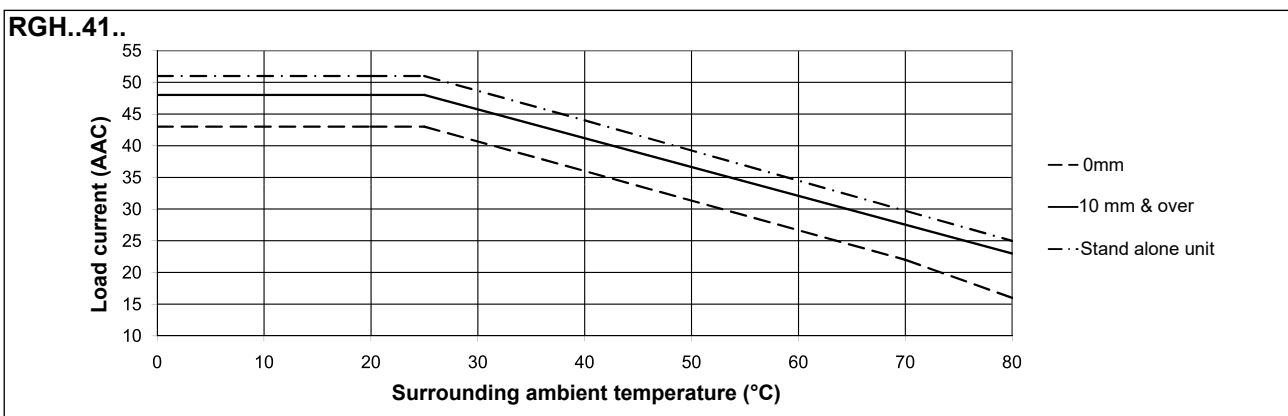
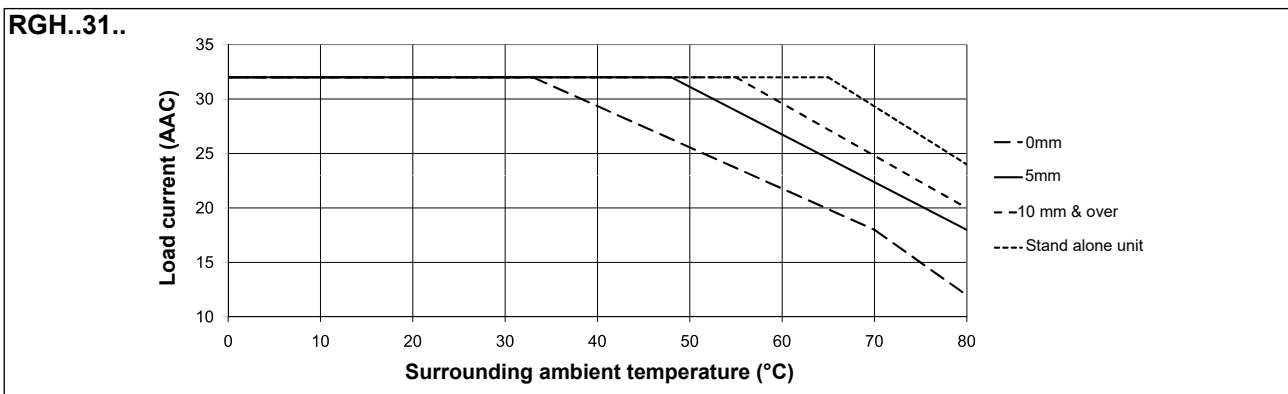
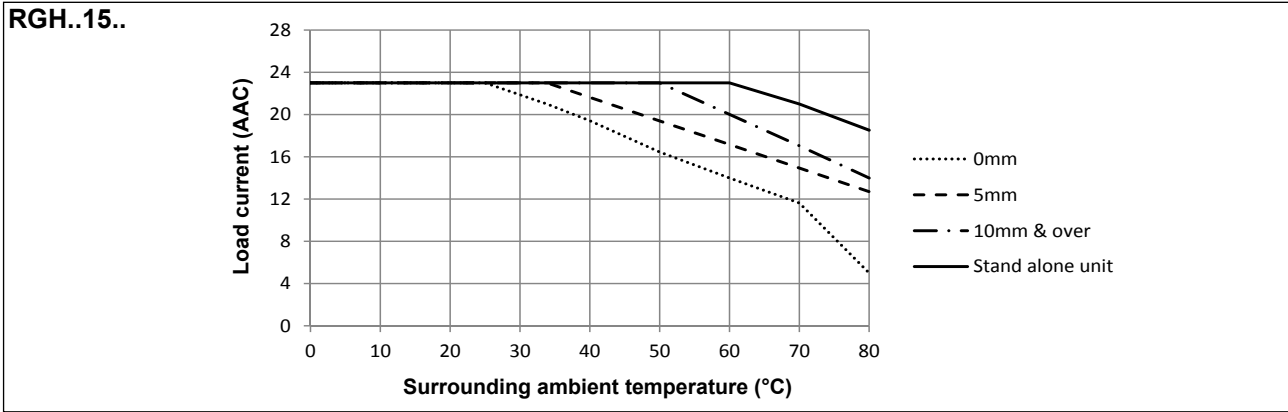

Derating vs. spacing curves



Compatibility and conformance

Approvals	   
Standards compliance	LVD: EN/IEC 60947-4-2, EN/IEC 60947-4-3 EMCD: EN/IEC 60947-4-3 UL: UL508 (E172877), NMFT cUL: C22.2 No. 14 (E172877), NMFT7 VDE: VDE 0660-109
UL short circuit current rating	100 kArms (refer to short circuit current section, Type 1 – UL508)

6: 690 VAC version is CE marked only

Electromagnetic compatibility (EMC) - Immunity	
Electrostatic discharge (ESD)	EN/IEC 61000-4-2 8 kV air discharge, 4 kV contact (PC1)
Radiated radio frequency	EN/IEC 61000-4-3 10 V/m, from 80 MHz to 1 GHz (PC1) 10 V/m, from 1.4 to 2 GHz (PC1) 10 V/m, from 2 to 2.7 GHz (PC1)
Electrical fast transient (burst)	EN/IEC 61000-4-4 Output: 2 kV, 5 kHz (PC1) Input: 1 kV, 5 kHz (PC1)
Conducted radio frequency	EN/IEC 61000-4-6 10 V/m, from 0.15 to 80 MHz (PC1)
Electrical surge⁷	EN/IEC 61000-4-5 Output, line to line: 1 kV (PC1) Output, line to earth: 2 kV (PC1) Input, line to line, 1kV (PC2) Input, line to earth, 2kV (PC2)
Voltage dips	EN/IEC 61000-4-11 0% for 0.5, 1 cycle (PC2) 40% for 10 cycles (PC2) 70% for 25 cycles (PC2) 80% for 250 cycles (PC2)
Voltage interruptions	EN/IEC 61000-4-11 0% for 5000 ms (PC2)

7: An external varistor, S20K750, needs to be connected across the mains supply for the RGH1A69.. models

Electromagnetic compatibility (EMC) - Emissions	
Radio interference field emission (radiated)	EN/IEC 55011 Class A: from 30 to 1000 MHz
Radio interference voltage emissions (conducted)	EN/IEC 55011 Class A: from 0.15 to 30 MHz (External filter may be required - refer to Filtering section)

Additional conformance to railway standards

Applicable to variants	RGH
Additional conformance specific to railway applications	EN 50155 EN 45545-2 EN 50121-3-2
Hazardous level conformance according to EN 45545-2	HL1, HL2 for requirement R23 HL1 for requirement R22
Operating temperature class according to EN 50155	OT3 (-25 °C to +70 °C)
Vibration and shock	EN 61373 Category 1, Class B
Additional EMC conformance	according to EN 50121-3-2
Radiated radio frequency immunity	EN/IEC 61000-4-3 20 V/m, from 80 MHz to 1 GHz (PC1) 10 V/m, from 1.4 to 2 GHz (PC1) 5 V/m, from 2 to 2.7 GHz (PC1) 3 V/m, 5.1 - 6 GHz (PC1)
Power quality measurement	EN/IEC 61000-4-30 50 Hz - 2 kHz, <8% THD (PASS)

Filter connection diagram

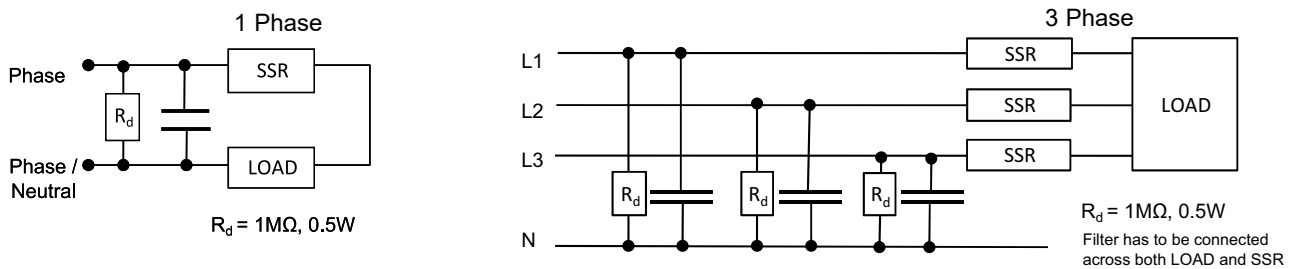

Filtering

Part number	Suggested filter for EN 55011 Class A compliance	Maximum heater current
RGH1A60..15	220 nF / 760V / X1	20 AAC
RGH1A60..31	220 nF / 760V / X1	30 AAC
RGH1A60..41	330 nF / 760V / X1	40 AAC
RGH1A60..60	330 nF / 760V / X1 680 nF / 760V / X1	40 AAC 65 AAC

Note:

- Control input lines must be installed together to maintain products' susceptibility to Radio Frequency interference.
- Use of AC solid state relays may, according to the application and the load current, cause conducted radio interferences. Use of mains filters may be necessary for cases where the user must meet E.M.C requirements. The capacitor values given inside the filtering specification tables should be taken only as indications, the filter attenuation will depend on the final application.
- This product has been designed for Class A equipment. Use of this product in domestic environments may cause radio interference, in which case the user may be required to employ additional mitigation methods.
- Performance Criteria 1 (PC1): No degradation of performance or loss of function is allowed when the product is operated as intended.
- Performance Criteria 2 (PC2): During the test, degradation of performance or partial loss of function is allowed. However when the test is complete the product should return operating as intended by itself.
- Performance Criteria 3 (PC3): Temporary loss of function is allowed, provided the function can be restored by manual operation of the controls.

Environmental specifications

Operating temperature	-40°C to +80°C (-40°F to +176°F)
Storage temperature	-40°C to +100°C (-40°F to +212 °F)
Relative humidity	95% non-condensing @ 40°C
Pollution degree	2
Installation altitude	0-1000 m. Above 1000 m derate linearly by 1% of FLC per 100 m up to a maximum of 2000 m
Vibration resistance	2g / axis (2-100Hz, IEC 60068-2-6, EN 50155, EN 61373)
Impact resistance	15/11 g/ms (EN 50155, EN 61373)
EU RoHS compliant	Yes
China RoHS	

The declaration in this section is prepared in compliance with People's Republic of China Electronic Industry Standard SJ/T11364-2014: Marking for the Restricted Use of Hazardous Substances in Electronic and Electrical Products.

Part Name	Toxic or Harardous Substances and Elements					
	Lead (Pb)	Mercury (Hg)	Cadmium (Cd)	Hexavalent Chromium (Cr(VI))	Polybrominat-ed biphenyls (PBB)	Polybromi-nated diphenyl ethers (PBDE)
Power Unit Assembly	x	o	o	o	o	o

O: Indicates that said hazardous substance contained in homogeneous materials fot this part are below the limit requirement of GB/T 26572.

X: Indicates that said hazardous substance contained in one of the homogeneous materials used for this part is above the limit requirement of GB/T 26572.

这份申明根据中华人民共和国电子工业标准 SJ/T11364-2014：标注在电子电气产品中限定使用的有害物质

零件名称	有毒或有害物质与元素					
	铅 (Pb)	汞 (Hg)	镉 (Cd)	六价铬 (Cr(VI))	多溴化联苯 (PBB)	多溴联苯醚 (PBDE)
功率单元	x	o	o	o	o	o

O:此零件所有材料中含有的该有害物低于GB/T 26572的限定。

X: 此零件某种材料中含有的该有害物高于GB/T 26572的限定。

Short circuit protection

Protection Co-ordination, Type 1 vs Type 2:

Type 1 protection implies that after a short circuit, the device under test will no longer be in a functioning state. In Type 2 co-ordination the device under test will still be functional after the short circuit. In both cases, however the short circuit has to be interrupted. The fuse between enclosure and supply shall not open. The door or cover of the enclosure shall not be blown open. There shall be no damage to conductors or terminals and the conductors shall not separate from terminals. there shall be no breakage or cracking of insulating bases to the extent that the integrity of the mounting of live parts is impaired. Discharge of parts or any risk of fire shall not occur.

The product variants listed in the table hereunder are suitable for use on a circuit capable of delivering not more than 100,000 Arms Symmetrical Amperes, 600 Volts maximum when protected by fuses. Tests at 100,000 A were performed with Class J fuses, fast acting; please refer to the table below for maximum allowed ampere rating of the fuse. Use fuses only.

Tests with Class J fuses are representative of Class CC fuses.

Protection co-ordination Type 1 according to UL 508				
Part No.	Prospective short circuit current [kArms]	Max fuse size [A]	Class	Voltage [VAC]
RGH1A60..15	100	30	J or CC	Max. 600
RGH1A60..31				
RGH1A60..41		40	J	
RGH1A60..60				

Protection co-ordination Type 2 (IEC/EN 60947-4-2/ -4-3)						
Part No.	Prospective short circuit current [kArms]	Ferraz Shawmut (Mersen)		Siba		Max. voltage [VAC]
		Max fuse size [A]	Part number	Max fuse size [A]	Part number	
RGH1A60..15	100	100	A70QS100-4	100	50 194 20.100	660
RGH1A60..31						
RGH1A60..41						
RGH1A60..60						
RGH1A69..41			A100P50-4		50 197 20.100	759
RGH1A69..60			-			

Protection co-ordination Type 2 with Minature Circuit Breakers (M.C.B.s)				
Solid State Relay type	ABB Model no. for Z - type M. C. B. (rated current)	ABB Model no. for B - type M. C. B. (rated current)	Wire cross sectional area [mm ²]	Minimum length of Cu wire conductor [m] ^a
RGH..15 RGH..31 RGH..41 RGH..60 (6600 A ² s)	S201 - Z20 (20A)	S201-B10 (10A)	1.5	4.2
			2.5	7.0
			4.0	11.2
	S201 - Z32 (32A)	S201-B16 (16A)	2.5	13.0
			4.0	20.8
			6.0	31.2
	S202 - Z20 (20A)	S202-B10 (10A)	1.5	1.8
			2.5	3.0
			4.0	4.8
	S202 - Z32 (32A)	S202-B16 (16A)	2.5	5.0
4.0			8.0	
6.0			12.0	
10.0			20.0	
S202 - Z50 (50A)	S202-B25 (25A)	4.0	14.8	
		6.0	22.2	
		10.0	37.0	

8. Between MCB and Load (including return path which goes back to the mains)

Note: A prospective current of 6 kA and a 230/400 V power supply is assumed for the above suggested specifications. For cables with different cross section than those mentioned above please consult Carlo Gavazzi's Technical Support Group.

S201 models refer to 1-pole M.C.B., S202 models refer to 2-poles M.C.B.

Dimensions

RGH1A..15KKE

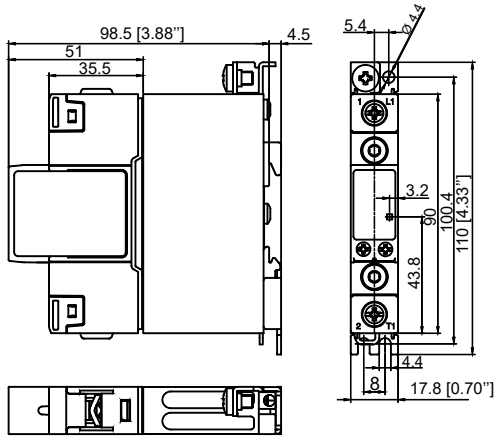

RGH1A..15MKE

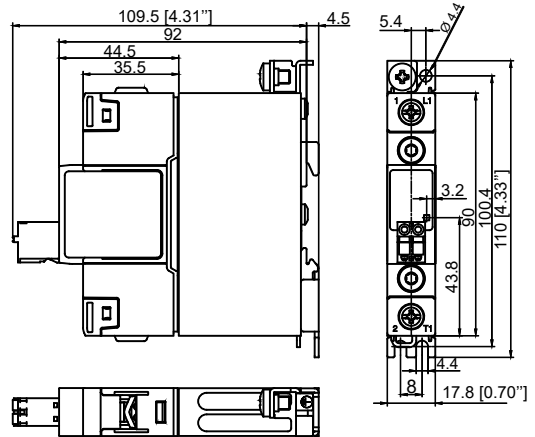

RGH1A..31KKE

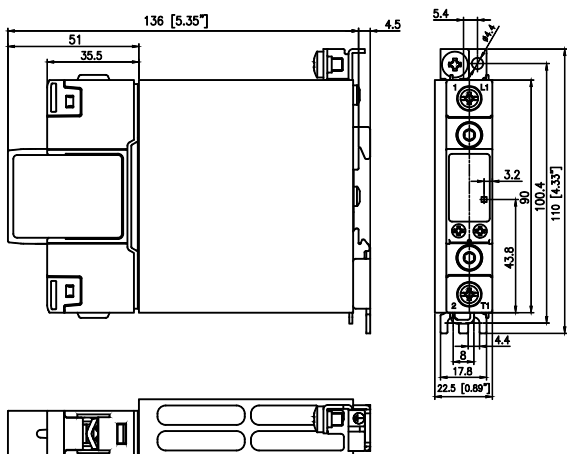

RGH1A..31MKE

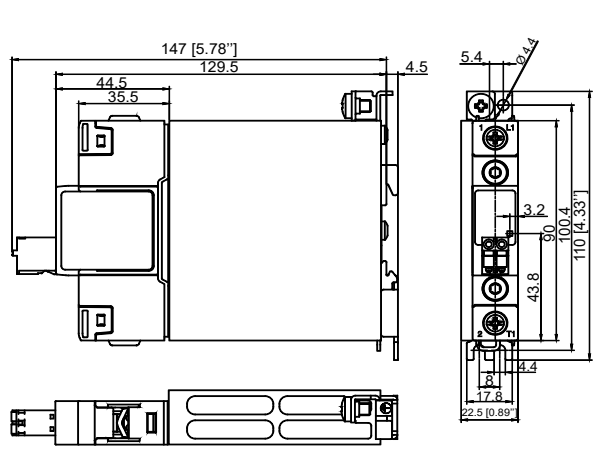

RGH1A..41KGE

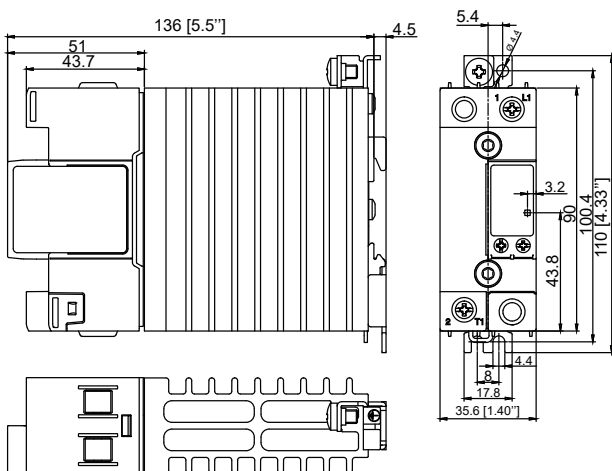

Housing width tolerance +0.5mm, -0mm as per DIN 43880. All other tolerances +/- 0.5mm. Dimensions in mm.

Dimensions - continued

RGC..60KGE

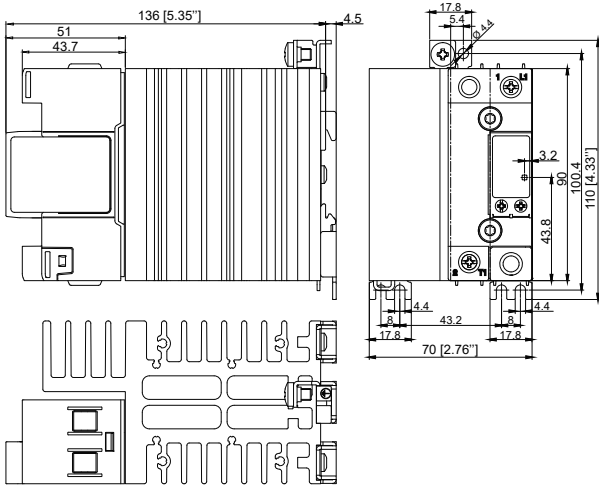

RGH1A...41KGU

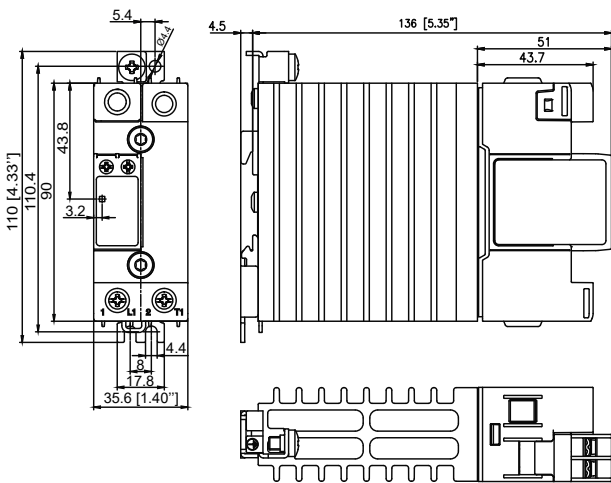

RGH1A...60KGU

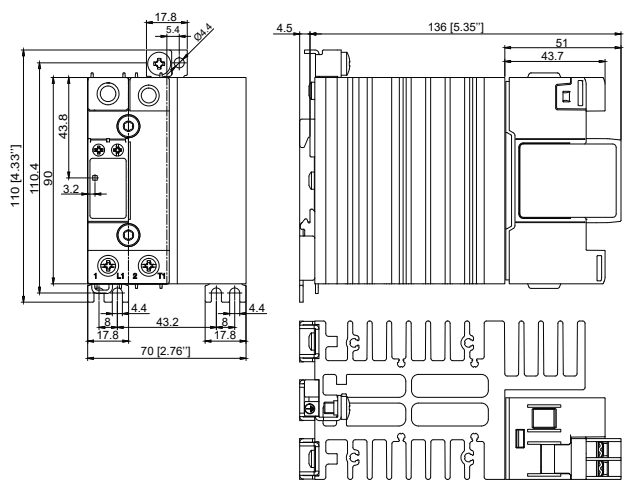

Housing width tolerance +0.5mm, -0mm as per DIN 43880. All other tolerances +/- 0.5mm. Dimensions in mm.

Terminal layout

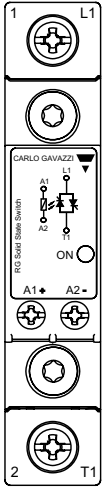

RGH1A..15KKE,
RGH1A..31KKE

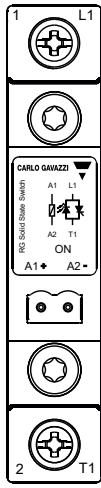

RGH1A..15MKE,
RGH1A..31MKE

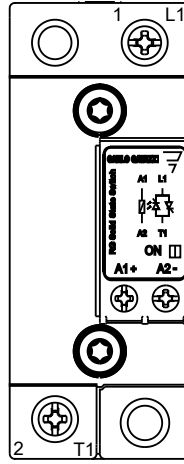

RGH1A...41KGE,
RGH1A...60KGE

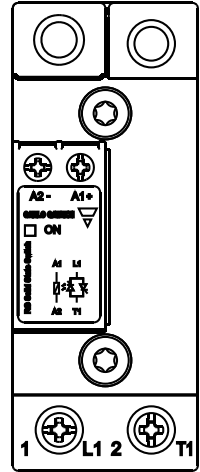

RGH1A...41KGU,
RGH1A...60KGU

- 1/L1: Mains supply connection
- 2/T1: Load connection
- A1(+): Positive control signal
- A2(-): Control ground
- ⊕: Protective Earth

Connection diagram

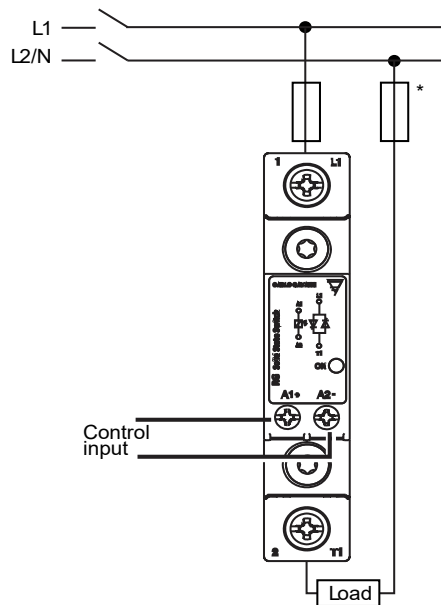

* depends on system requirements

Functional diagram

DC control

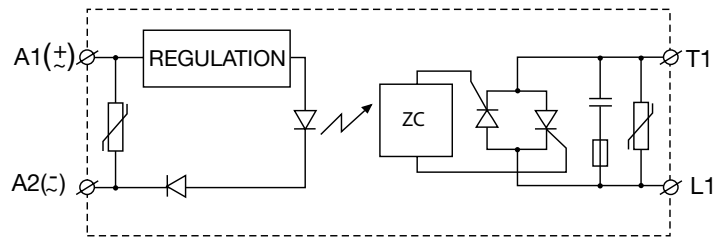
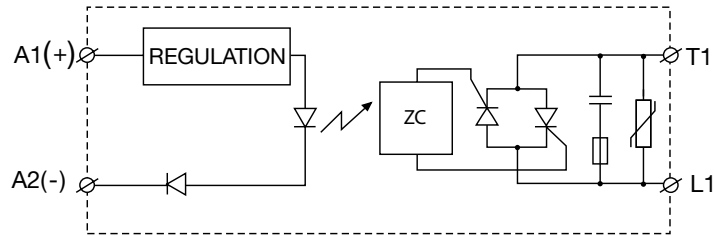

Note: Varistor on output is not included in the RGH1A69...models

Installation

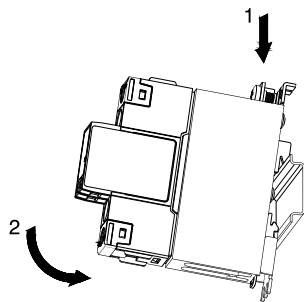

Mounting on DIN rail

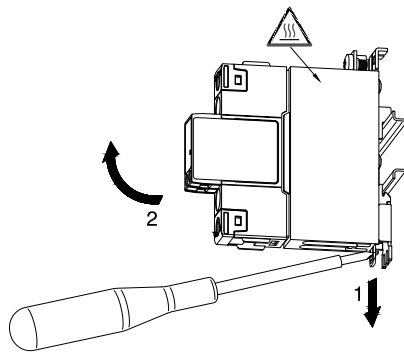

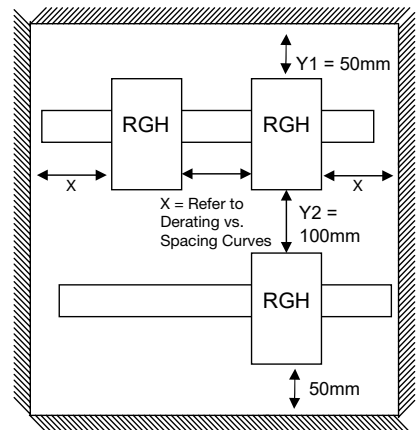

Dismounting from DIN rail

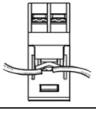
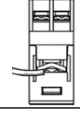
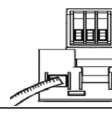

Connection Specifications

Power connections			
Terminals	1/L1, 2/T1		
Conductors	Use 75°C copper (Cu) conductors		
	RGH..KKE, RGH..MKE	RGH..KGE, RGH..MGE, RGH..KGU	
			
Connection type	M4 screw with captivated washer		M5 screw with box clamp
Stripping length	12 mm		11 mm
Rigid (solid & stranded) UL/cUL rated data	2x 2.5 – 6.0 mm ² 2x 14 – 10 AWG	1x 2.5 – 6.0 mm ² 1x 14 – 10 AWG	1x 2.5 – 25.0 mm ² 1x 14 – 3 AWG
Flexible with end sleeve	2x 1.0 – 2.5 mm ² 2x 2.5 – 4.0 mm ² 2x 18 – 14 AWG 2x 14 – 12 AWG	1x 1.0 – 4.0 mm ² 1x 18 – 12 AWG	1x 2.5 – 16.0 mm ² 1x 14 – 6 AWG
Flexible without end sleeve	2x 1.0 – 2.5 mm ² 2x 2.5 – 6.0 mm ² 2x 18 – 14 AWG 2x 14 – 10 AWG	1x 1.0 – 6.0 mm ² 1x 18 – 10 AWG	1x 4.0 – 25.0 mm ² 1x 12 – 3 AWG
Torque specifications	Pozidriv bit 2 UL: 2.0 Nm (17.7 lb-in) IEC: 1.5 – 2.0 Nm (13.3 – 17.7 lb-in)		Pozidriv bit 2 UL: 2.0 Nm (17.7 lb-in) IEC: 2.0 – 2.5 Nm (13 – 17.7 lb-in)
Aperture for termination lug (fork or ring)	12.3 mm		n/a
Protective Earth (PE) connection	M5, 1.5 Nm (13.3 lb-in) M5 PE screw is not provided with the solid state relay. PE connection is required when product is intended to be used in Class 1 applications according to EN/IEC 61140		

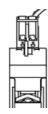
Control connections			
Terminals	A1+, A2-		
Conductors	Use 60/75°C copper (Cu) conductors		
	RGH..KKE, RGH..KGE, RGH..KGU screw control terminal	RGH..MKE, RGH..MGE spring plug control terminal	
			
Connection type	M3 screw with captivated washer		Spring loaded
Stripping length	8 mm		12-13 mm
Rigid (solid & stranded) UL/cUL rated data	2x 0.5 - 2.5 mm ² 2x 18 - 12 AWG	1x 0.5 - 2.5 mm ² 1x 18 - 12 AWG	1x 0.2 - 2.5 mm ² 1x 24 - 12 AWG
Flexible with end sleeve	2x 0.5 - 2.5 mm ² 2x 18 - 12 AWG	1x 0.5 - 2.5 mm ² 1x 18 - 12 AWG	
Torque specification	Pozidriv 1 UL: 0.5 Nm (4.4 lb-in), IEC: 0.4-0.5 Nm (3.5 - 4.4 lb-in)		

Bulk packaging option

- Packing qty.: 20 pcs.
- Total weight: 4.75 kg

Applicable only to RGH..15



COPYRIGHT ©2026
Content subject to change.
Download the PDF: <https://gavazziautomation.com>